



# XEFT-03EU-EMRV

Project \_\_\_\_\_

Item \_\_\_\_\_

Quantity \_\_\_\_\_

Date \_\_\_\_\_

**Model**  
**BAKERLUX SHOP.Pro™ MASTER**

Convection oven + humidity	Electric
3 trays 600x400	Hinge on the left side
7" Touch control panel	
Automatic opening	
Voltage: 220-240V 1~	

## Description

Convection oven, ideal for baking breakfast and snack products, in particular pastry and frozen bakery ones. Humidity setting, 2 programmable fan speeds and 304 stainless steel cooking chamber. The 7" touch digital panel allows the storage of the cooking programs together with their image and name. Automatic management of the cooking processes (CHEFUNOX) to achieve perfect cooking results even without qualified staff. Ready to be connected to the Internet and use the [datadrivencooking.com](http://datadrivencooking.com) portal.



## Standard cooking features

### Programs

- **384 Programs**
- **CHEFUNOX:** choose something to cook from the library and the oven will automatically set all the parameters
- **MULTI.TIME:** manages up to 10 cooking processes at the same time
- **READY.BAKE:** ready to use settings with infinite time for a quick start

### Manual cooking

- **Temperature:** 30 °C – 260 °C
- Up to 9 cooking steps
- Humidity set by 20%

### Key features

- Cooking chamber in high-resistance AISI 304 stainless steel with rounded edges
- Double glass
- Cooking chamber lighting through LED lights embedded in the door
- Baking chamber with chrome-plated steel rack rails
- 2-speed fan system and high-performance circular heating elements
- **Wi-Fi / USB data:** download/upload HACCP data
- **Wi-Fi / USB data:** download/upload programs

## Advanced and automatic cooking features

### Unox Intelligent Performance

- **ADAPTIVE.Cooking™:** automatically regulates the cooking parameters to ensure repeatable results
- **SMART.Preheating:** automatically sets the preheating temperature and duration
- **AUTO.Soft:** manages the heat rise to make it more delicate

### Unox Intensive Cooking

- **DRY.Plus:** rapidly extracts humidity from the cooking chamber
- **STEAM.Plus:** creates instant humidity
- **AIR.Plus:** multiple fans with reverse gear and 2 speed settings

### App and web services

- **Data Driven Cooking app & webapp:** check and monitor in real-time the operating conditions of your ovens, create and share new recipes. Artificial intelligence transforms consumption data into useful information and allows you to increase daily profits
- **Top Training app:** download the Unox Top.Training app and learn step by step all the secrets of your new oven's control panel



# XEFT-03EU-EMRV

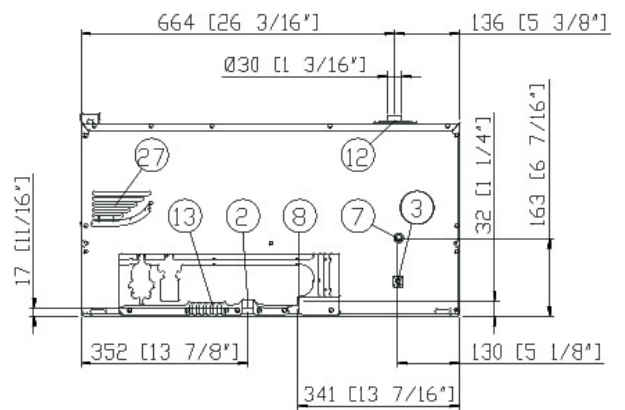
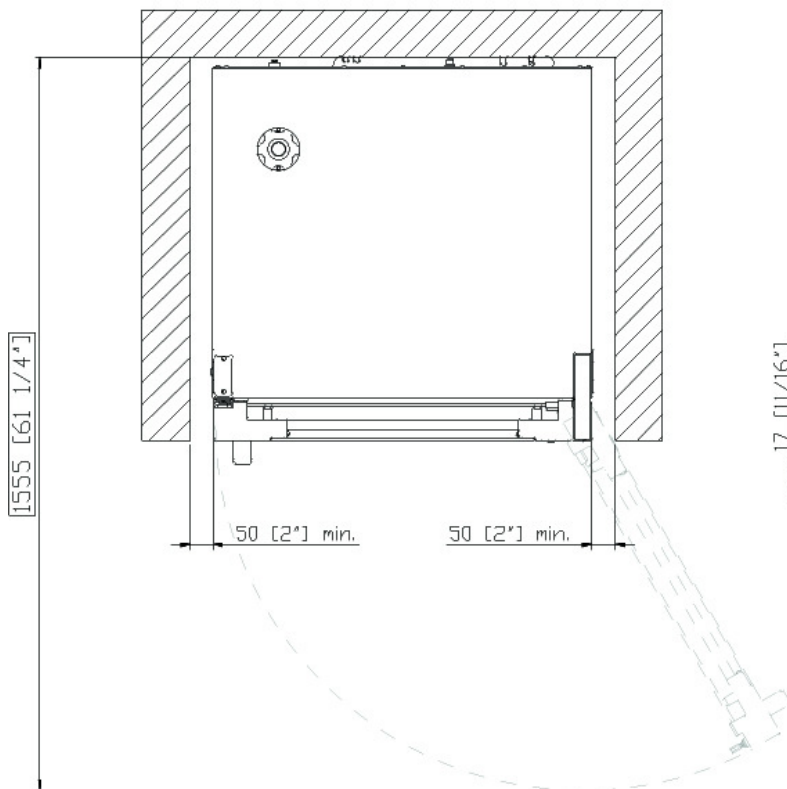
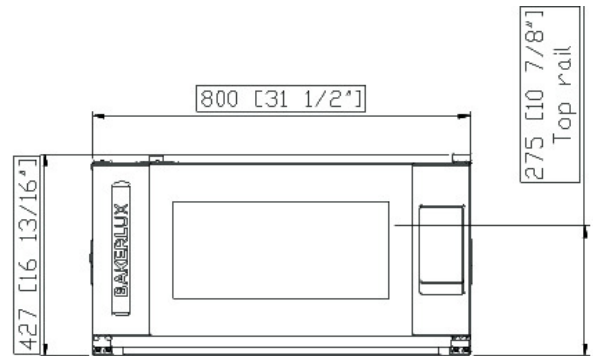
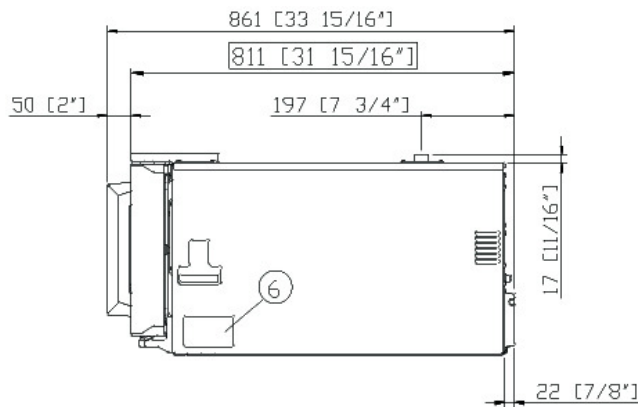

## Dimensions and weight

<b>Width</b>	800 mm
<b>Depth</b>	811 mm
<b>Height</b>	427 mm
<b>Net weight</b>	46 kg
<b>Tray pitch</b>	75 mm

## Connection positions

<b>2</b>	Terminal board power supply
<b>3</b>	Unipotential terminal
<b>6</b>	Technical data plate
<b>7</b>	Safety thermostat
<b>8</b>	3/4" female NPT water inlet
<b>12</b>	Hot fumes exhaust chimney

<b>13</b>	Accessories connection
<b>27</b>	Cooling air outlet



# XEFT-03EU-EMRV

Power supply

Water connection

Installation requirements

Accessories

## Electrical power supply

### STANDARD

Voltage	220-240 V
Phase	~1PH+PE
Frequency	50 / 60 Hz
Total power	3,5 kW
Max Amp draw	15 A
Required breaker size	16 A
Power cable requirements*	3G x 1,5 mm <sup>2</sup>
Plug	Schuko

\*Recommended size - observe local ordinance.

## Accessories

- **Ventless hood:** steam condensing hood
- **Waterless hood:** filters odours and absorbs latent heat coming out of the cooking chamber without using water
- **DECKTOP:** traditional baking on stone, convection baking and combi cooking
- **LIEVOX:** Proofer equipped with sensors capable to control and intervene automatically on the leavening process
- **Stand:** the multifunctional support ideal for storing trays safely and placing your oven at the perfect height to work
- **Baking Essentials:** special trays
- **SPRAY&Rinse:** Practical spray detergent to manually clean all kinds of oven. It degreases and removes all kind of dirt
- **PURE:** resin-based filtering system that eliminates from the water all substances that contribute to the formation of limescale inside the oven cooking chamber
- **Wi-Fi / Ethernet:** Connection board to keep the oven connected to Unox cloud, mandatory to extend the warranty
- **Ethernet:** Connection board to keep the oven connected to Unox and DDC.App

## Water Supply

USING A WATER SUPPLY THAT DOES NOT MEET UNOX'S MINIMUM WATER QUALITY STANDARDS WILL VOID ANY WARRANTY.

It is the responsibility of the purchaser to ensure that the incoming water supply is compliant with the listed specifications through adequate treatment measures.

Drinking water inlet: 3/4" NPT\*, line pressure:

**Line pressure:** 22 to 87 psi; 1.5 to 6 Bar (29 psi; 2 Bar recommended)

### Inflow water specifications

**Free chlorine** ≤ 0.5 ppm

**Chloramine** ≤ 0.1 ppm

**pH** 7 - 8.5

**Electrical conductivity** ≤ 1000 µS/cm

**Total hardness** ≤ 30° dH

### Steam circuit: inflow water specifications

**Chlorides** ≤ 120 ppm

**Total hardness** ≤ 8 °dH

To avoid the formation of limescale the incoming water must have total hardness ≤ 8°dH.

## Installation requirements

Installations must comply with all local electrical systems, particularly as for minimum wire gauge required for field connection, hydraulic and ventilation supply. Exhaust and fume analysis must be performed in case of gas ovens.

Register to DDC Service to access data and product specifications.

[www.ddc.unox.com](http://www.ddc.unox.com)