

CFMC4-66ET

60 MAGICLOTUS ELECTRIC COOKERS

Range threephase - Ceramic, Glass: cm.
58x44 Multifunction oven - Chamber cm.
46x37x35h, temp: 50÷250°C, with 1 grid
cm.41x32,5 - Glass door



Construction - Fabricated using CrNi 18/10 AISI 304 grade Stainless Steel Scotch-Brite Satin polish Finish, incorporating 1mm thick worktop, rounded edges, chromed details and rear splash back. Knobs with waterproof grades IPX5. Model - Professional Electric Cooker with static or multifunction electric oven. Cast Iron round hot plates with steel border seals, seven position switch and temperature limiter. Ceramic glass tops with radiant heat hot plates and warning lights for residual heat, electric oven with 50 - 300degC control. Maintenance - All serviceable parts are accessible by the easy removal of front control panel. Fittings - Appliance is supplied with adjustable feet.

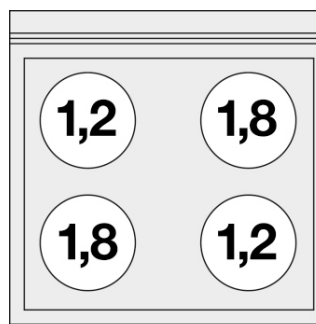

ITALIAN CULINARY ART

The pictures are purely representative. The manufacturer reserves the right to modify the technical data and models without previous notice.

CFMC4-66ET

60 MAGICLOTUS
ELECTRIC COOKERS

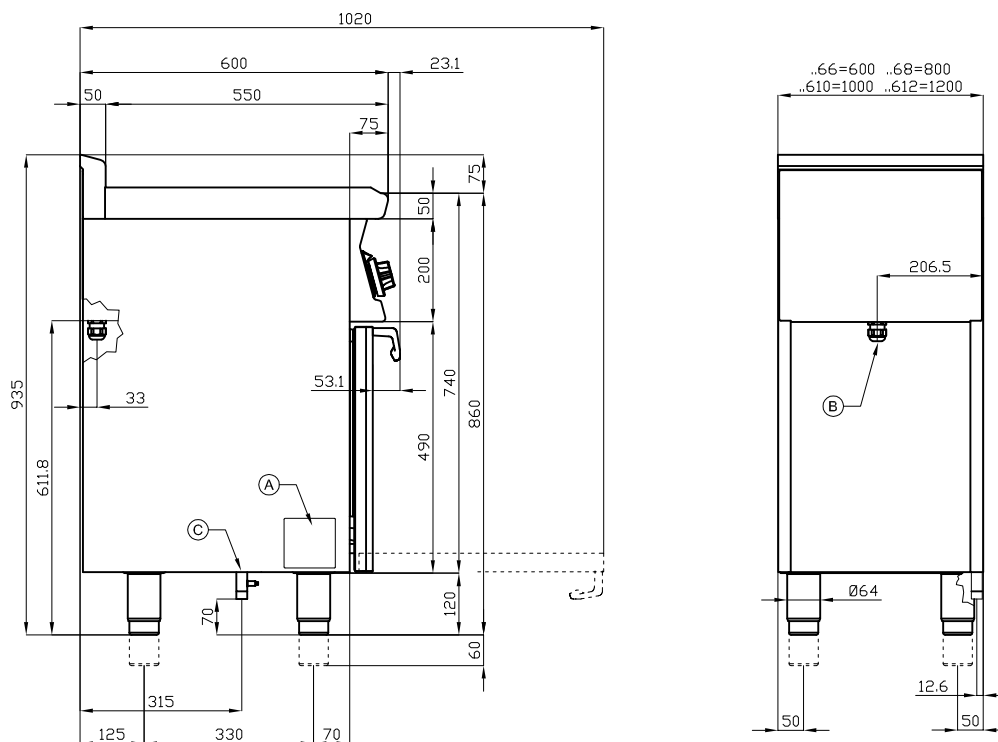

A	Data plate		B	Electrical connection	
---	------------	--	---	-----------------------	--

MODEL: CFMC4-66ET
DIMENSIONS: cm. 60x 60x 90h
ELECTRIC POWER: 9,05 kW
VOLTAGE: 400V~3N / 230V~3 / 230V~
FREQUENCY: 50/60 Hz



kg: 70
m³: 0.469
mm: 630x670x1110

BUY LOTUS BUY ITALY

The pictures are purely representative. The manufacturer reserves the right to modify the technical data and models without previous notice.



LOTUS S.P.A. Via Calmaor, 46
31020 San Vendemiano(TV) - Italy
Tel. + 39 0438 778020 / 778468
Fax + 39 0438 778277
www.lotuscookers.it - lotus@lotuscookers.it