



BLENDER B-20

Professional beater. 300 W.



SPECIFICATIONS

Total loading: 300 W
Motor speed: 200 - 1800 rpm
Capacity (egg whites): 2 - 30
Plug: --

Length

Revolving arm length: 306 mm
Total length (with revolving arm): 570 mm

Net weight: 2.62 Kg
Noise level (1m.): <80 dB(A)

Crated dimensions

440 x 375 x 105 mm
Gross weight: 3.3 Kg

AVAILABLE MODELS

3030636 Whisk B-20 230/50-60/1

* Ask for special versions availability

SALES DESCRIPTION

- ✓ Variable speed motor block.
- ✓ Whisk with capacity for 2 to 30 egg whites.

Professional performance

- ✓ Vario-speed: variable speed.
- ✓ Beater with capacity for 2 to 30 egg whites.

Maximum comfort for the user

- ✓ Compact design: logical and manageable size.
- ✓ Ergo-design & bi-mat-grip: external casing made in two materials for an ergonomic hold. Anti-slip grip. Optimum inclination of handle, minimising fatigue.
- ✓ Click-on-arm: detachable arm with fast and secure closure.
- ✓ Intuitive use: very simple operation. Warning light when the machine is connected to the mains.

Built to last

- ✓ Professional performance: capable of carrying out prolonged work without the casing overheating.
- ✓ Life-plus: equipped with a motor which has passed all of the most demanding usage tests.
- ✓ Studied geometry: casing designed to avoid rolling and falling.
- ✓ Easy to clean: detachable arm, can be cleaned under the tap.
- ✓ Approved by NSF: guaranteed safety and hygiene.

INCLUDES

- ✓ Variable speed motor block.
- ✓ Wall mount.
- ✓ Whisk BA-20.

OPTIONAL

- MA-21 mixer arm.
- MA-22 mixer arm.

DYNAMIC PREPARATION
COMMERCIAL HAND BLENDERS

product sheet
updated 13/03/2023



SAMMIC, S.L.
Bassaïre, 1 - 20720 Azzovita
www.sammic.com





BLENDER B-20

Professional beater. 300 W.

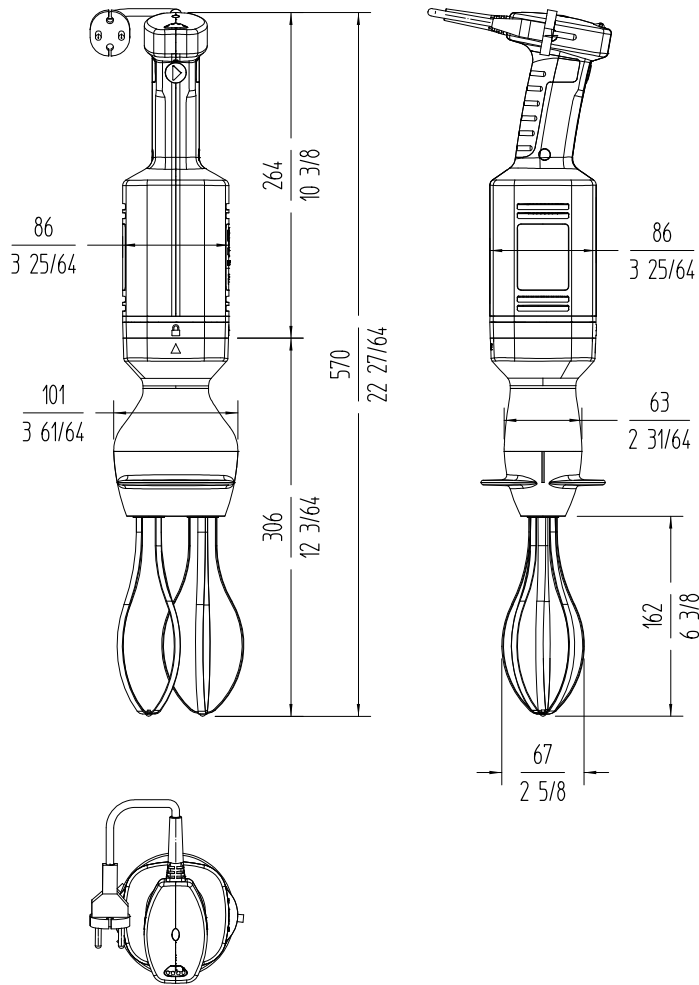

DYNAMIC PREPARATION
COMMERCIAL HAND BLENDERS



 **sammic** | www.sammic.com
Food Service Equipment Manufacturer
Polígono Basarte, 1. phone +34 943 15 72 36
20720 Azkoitia, Spain sales@sammic.com



Project	Date
Item	Qty
Approved	

product sheet
updated 13/03/2023